

CATALOGUE

D A T A

CSX Series Soft Starters



AuCom

AuCom's new CSX Series includes two ranges. Users can choose between a simple soft start control device and an advanced soft start system complete with motor protection. This choice allows selection of a soft start product best suited to an individual application.

The CSX range is a TVR system that provides soft start and soft stop functionality in a very compact frame.

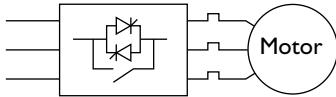

The CSXi range is a Constant Current system with current measurement and control. It provides a range of motor protection functions in addition to soft start and soft stop.

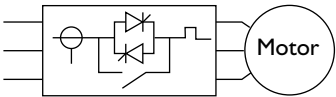

Power Range 7.5kW~110kW @ 400V
Supply Voltage 3 x 200~440 VAC or
3 x 200~575 VAC

Supply Frequency 45Hz~66Hz
Control Voltage 110~240VAC, 380~440 VAC or
24 VAC / VDC

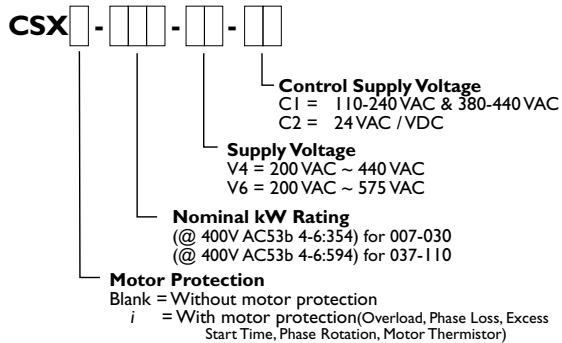

- Compact design, small footprint
- Simple set-up and installation
- Built-in bypass contactor
- Excellent start ratings and duty
- IP20 up to 55kW
- DIN rail mounting up to 30kW
- CE, UL, C-UL, C✓ approvals

FEATURE SET

| | CSX | CSXi |
|----------------------------------|-----|------|
| Starting | | |
| TVR (Timed voltage ramp) | ✓ | |
| Constant Current | | ✓ |
| Current Ramp | | ✓ |
| Stopping | | |
| Soft Stop | ✓ | ✓ |
| Protection | | |
| Motor Overload | | ✓ |
| Phase Imbalance | | ✓ |
| Phase Sequence | | ✓ |
| Excess Start Time | | ✓ |
| Motor Thermistor | | ✓ |
| Supply Fault | ✓ | ✓ |
| Shorted SCR | ✓ | ✓ |
| LED Indication | | |
| Ready/Tripped | ✓ | ✓ |
| Running/Starting-Stopping | ✓ | ✓ |
| Fault Code | ✓ | ✓ |
| Relay Outputs | | |
| Main Contactor | ✓ | ✓ |
| Run | | ✓ |
| Tripped | | ✓ |
| Options & Accessories | | |
| Remote Operator | ✓ | ✓ |
| 4-20mA Output | | ✓ |
| PC Software | ✓ | ✓ |
| AS-i | ✓ | ✓ |
| Modbus RTU | ✓ | ✓ |
| Profibus | ✓ | ✓ |
| DeviceNet | ✓ | ✓ |

| Model | kW | Height mm | Width mm | Depth mm |
|-------|-----|--------------|-------------|-------------|
| 007 | 7 | 203 | 98 | 163 |
| 015 | 15 | | | |
| 018 | 18 | | | |
| 022 | 22 | | | |
| 030 | 30 | 215 | 145 | 191 |
| 037 | 37 | | | |
| 045 | 45 | | | |
| 055 | 55 | 240 | 202 | 212 |
| 075 | 75 | | | |
| 090 | 90 | | | |
| 110 | 110 | | | |

