



VALIADIS
HELLENIC MOTORS

KA-A series





KA-A-series 160-280

Standard features

- Vertical hollow shaft motors for deep well pumps
- WP1 protection degree
- Insulation class F temperature rise 80°C
- SKF or NSK bearings
- PTC protection for the windings
- Heavy duty thrust bearing on the top side
- Oil lubrication for the DE bearing

Options

- PT100 in the winding
- Water cooled DE bearing

KA-A-series

Three-phase Vertical Hollow Shaft motors with squirrel cage, protection degree WP1

NEMA DESIGN
4 POLES-1.500 Rpm
 660-725/380-420 V Y/Δ 50 Hz
 Insulation class F

TYPE	Power		Speed	Efficiency	Power factor	Rated current (400V)	Nominal torque	Starting current ratio	Starting torque ratio	Break-down torque	Down-thrust load	Net weight
	KW	HP	Rpm	%	συμφ	Amp	Nm	Ip/In	Mp/Mn	Mm/Mn	lb	Kg
KA-A 160	11	15	1460	86,5	0,85	22	72	7	1,8	2	3.740	236
KA-A 160	15	20	1485	87,5	0,86	29	96	7	1,8	2	3.740	248
KA-A 180	18,5	25	1465	88,0	0,86	35	121	7	1,7	2	3.740	305
KA-A 180	22	30	1470	88,5	0,86	42	143	7	1,7	2	3.740	310
KA-A 200	30	40	1480	89,5	0,87	56	194	7	1,7	2	5.000	390
KA-A 200	37	50	1480	90,0	0,87	68	239	7	1,7	2	5.000	410
KA-A 200	45	60	1480	90,5	0,87	83	290	7	1,7	2	5.000	430
KA-A 250	55	75	1480	91,0	0,88	99	355	7	1,7	2	8.800	660
KA-A 250	75	100	1480	91,5	0,88	135	484	7	1,7	2	8.800	700
KA-A 250	90	125	1480	91,5	0,88	162	581	7	1,7	2	8.800	730
KA-A 280	110	150	1490	92,0	0,88	196	705	7	1,7	2	11.600	940
KA-A 280	132	180	1490	92,5	0,88	234	846	7	1,7	2	11.600	990
KA-A 280	150	200	1490	92,5	0,88	266	961	7	1,7	2	11.600	1.020
KA-A 280	185	250	1490	92,5	0,88	328	1186	7	1,7	2	11.600	1.140
KA-A 280	200	270	1490	93,0	0,88	353	1282	7	1,7	2	11.600	1.190
KA-A 280	220	300	1490	93,0	0,88	388	1410	7	1,7	2	11.600	1.240

BEARINGS VERTICAL HOLLOW SHAFT MOTORS

FRAME	THRUST	GUIDE
	4p	4p
160	7314B	6211-Z
180	7315B	6212-Z
200	7318B	6213-Z
250	7322B	6317-Z
280	7328B	6318-Z

KA-A-series

Dimension sheet

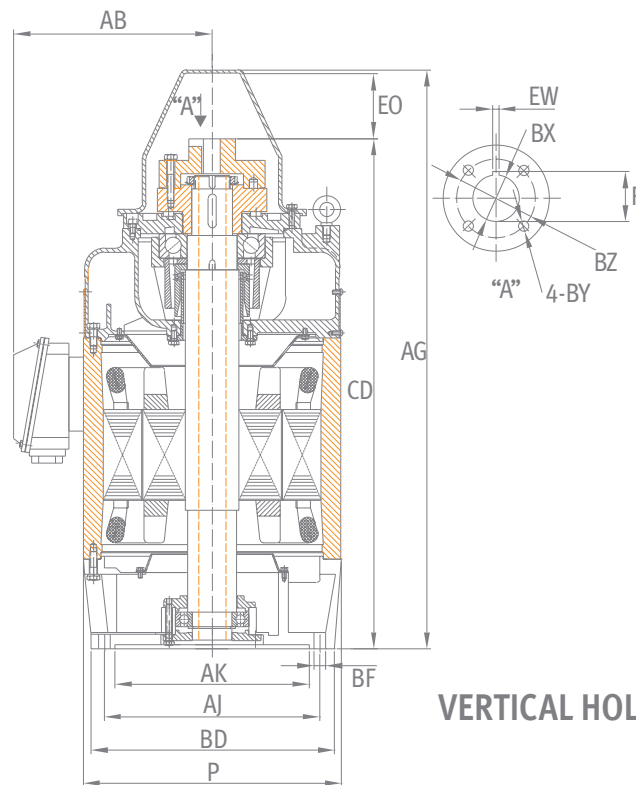

**VERTICAL HOLLOW SHAFT MOTORS
NEMA DESIGN
SIZES 160 - 280**

TYPE	Power		Dimensions in inches													
	KW	HP	BD	AJ	AK	BF	BX	BZ	EW	R	BY	CD	EO	P	AB	AG
KA-A 160	11	15	12	9,125	8,25	0,44	1,001	1,375	0,25	1,114	10x32	29,02	3,15	13,8	10,4	32,9
KA-A 160	15	20														
KA-A 180	18,5	25	16,5	14,75	13,5	0,69	1,001	1,375	0,25	1,114	10x32	30,31	3,54	15,6	11,4	34,3
KA-A 180	22	30														
KA-A 200	30	40	16,5	14,75	13,5	0,69	1,188	1,75	0,25	1,304	1/4x20	34,29	3,74	17,5	13	38,6
KA-A 200	37	50														
KA-A 200	45	60														
KA-A 250	55	75	16,5	14,75	13,5	0,69	1,188	1,75	0,25	1,304	1/4x20	45	4,13	21,3	15,60	50
KA-A 250	75	100														
KA-A 250	90	125	16,5	14,75	13,5	0,69	1,438	2,125	0,375	1,605	1/4x20	45	4,13	21,3	15,6	50
KA-A 280	110	150	16,5	14,75	13,5	0,69	1,688	2,5	0,375	1,859	1/4x20	51,62	4,72	23,6	17,5	57,7
KA-A 280	132	180														
KA-A 280	150	200														
KA-A 280	185	250	20	14,75	13,5	0,69	1,938	2,5	0,5	2,16	1/4x20	53,5	4,72	23,6	21,26	58,5
KA-A 280	200	270														
KA-A 280	220	300														



ATHENS: 18, Gr. Lambraki Str., 141 23 Likovrisi – tel: +30 2102817217, fax : +30 2102814277

THESSALONIKI: Industrial Area of Sindos., O.T. 48B, 15th Str., 570 22

tel: +30 2310796646 – fax: +30 2310796645

e-mail: valiadis@valiadis.gr – <https://www.valiadis.gr>

ROMANIA: 1, Aleea Meseriasilor, Bloc C93, Etaj 2, Ap. 16, Sector 6, 061647-Bucharest

tel: +40 214135902 – e-mail: romania@valiadis.gr – <https://www.ac-motors.eu>